

**KLT-C7K-OV8858-A2B****OmniVision OV8858 MIPI Interface Auto-foco 8MP Módulo de Câmera**

<b>Módulo de câmara No.</b>	<b>KLT-C7K-OV8858-A2B</b>
<b>Sensor de imagem</b>	OV8858
<b>EFL</b>	2.93 mm
<b>F.NO</b>	2.0
<b>Pixel</b>	3264 x 2448
<b>Ângulo de visão</b>	75°
<b>Tipo de lente</b>	1/4 polegada
<b>Dimensões da lente</b>	8.5 x 8.5 x 5.4 mm
<b>Tamanho do Módulo</b>	22.9 x 8.5 mm
<b>Tipo de Módulo</b>	Auto-foco
<b>Interface</b>	MIPI

**Acasalamento Parte conector No. DF30FC-30DS-0.4V**

Conector de acoplamento na placa principal. Vendido separadamente.



# OV8858 8MP product brief



available in  
a lead-free  
package

## Cost-Effective 1/4-Inch 8-Megapixel Image Sensor with Video-in-Video Support for Mainstream Mobile Devices

OmniVision's OV8858 is a 1/4-inch 8-megapixel PureCel™ image sensor for the rapidly growing mainstream smartphone and tablet market. The compact and cost-effective OV8858 sensor delivers dramatically reduced power consumption and best-in-class performance, making it a highly competitive solution for the next-generation of mobile devices.

Compared to OmniVision's previous-generation 1/4-inch 8-megapixel sensor, the OV8858 delivers a number of performance enhancements, including dramatically improved full-well capacity (FWC) and sensitivity for enhanced high- and low-light performance. It also offers a significant reduction in power consumption and form factor.

The sensor also features OmniVision's Video-in-Video (ViV™) technology, which stitches together images from the front- and rear-cameras, applies enhancements such as independent lens correction and color compensation, and sends the combined image to the host ISP. In ViV mode, users can capture a portrait scene perfectly alongside their own face, record video while narrating for

high quality video blogging, or utilize the feature for video conferencing. This is made possible by a special input MIPI receiver on the OV8858 that can accept image data from a wide range of OmniVision image sensors designed for front-facing applications of 2-megapixel and below, thus saving a camera port on the host ISP.

The OV8858 supports an active array of 3264 x 2448 pixels (8-megapixel) operating at 30 frames per second (fps) for zero shutter lag, enabling high-speed photography. The sensor is capable of recording 1080p high definition (HD) video at 60 fps, or 720p HD video at 90 fps, each with additional pixels for electronic image stabilization (EIS). The OV8858, when paired with OmniVision's latest 2-megapixel sensors, can provide full resolution ViV snapshot images at 15 fps and preview ViV video at 30 fps.

The OV8858 fits into an 8.5 x 8.5 mm camera module with a build height of approximately 4 mm.

Find out more at [www.ovt.com](http://www.ovt.com).



## Applications

- Cellular Phones
- Tablets
- PC Multimedia

## Product Features

- PureCel™ image sensor
- 1.12 μm x 1.12 μm pixel with ViV™ technology
- optical size of 1/4"
- 32.9° CRA for -4mm Z-height
- programmable controls for frame rate, mirror and flip, cropping, and windowing
- supports images sizes: 8MP (4.3 - 3264x2448), 8MP (16.9 - 3264x1836), EIS 1080p (2112x1188), 1080p (1920x1080), EIS 720p (1408x792), and more
- 8MP at 30 fps
- two-wire serial bus control (SCCB)
- frame exposure mode for still image (with mechanical shutter)
- 4k bits of embedded one-time programmable (OTP) memory for customer use
- supports Video-in-Video (ViV) mode using an on-chip 1-lane MIPI receiver and a secondary sensor
- special ViV features include: ViV video at up to 30 fps, ViV snapshot at up to 15 fps, arbitrary positions and shapes for ViV window, separate AWB compensation for secondary sensor, and more
- two on-chip phase lock loops (PLLs)
- image quality control: defect pixel correction, automatic black level calibration, lens shading correction
- alternate row HDR
- built-in temperature sensor
- suitable for module size of 8.5 mm x 8.5 mm x -4 mm

# OV8858



## Ordering Information

- OV8858-G04A-Z (color, chip probing, 200 μm backgrinding, reconstructed wafer with good die)

## Product Specifications

- active array size: 3264 x 2448
- power supply:
  - analog: 2.6 to 3.0V (2.8V nominal)
  - core: 1.14 to 1.26V (1.2V nominal)
  - I/O: 1.7 to 3.0V (1.8V or 2.8V nominal)
- power requirements:
  - active: 153 mW
  - standby: 160 μW
  - XSHUTDOWN: 0.3 μW
- temperature range:
  - operating: -30°C to +85°C junction temperature
  - stable image: 0°C to +60°C junction temperature
- output formats: up to 4-lane MIPI serial output
- output formats: 10-bit RAW RGB data
- lens size: 1/4"
- lens chief ray angle: 32.9° non-linear
- input clock frequency: 6 - 27 MHz
- maximum image transfer rate:
  - 3264x2448: 30 fps
  - 3264x1836: 30 fps
  - 2112x1184: 60 fps
  - 1920x1080: 60 fps
  - 1408x792: 90 fps
- scan mode: progressive
- pixel size: 1.12 μm x 1.12 μm
- image area: 3678.3 μm x 2767.68 μm
- package/die dimensions:
  - COB: 5040 μm x 4590 μm
  - RW: 5090 μm x 4640 μm

## Functional Block Diagram

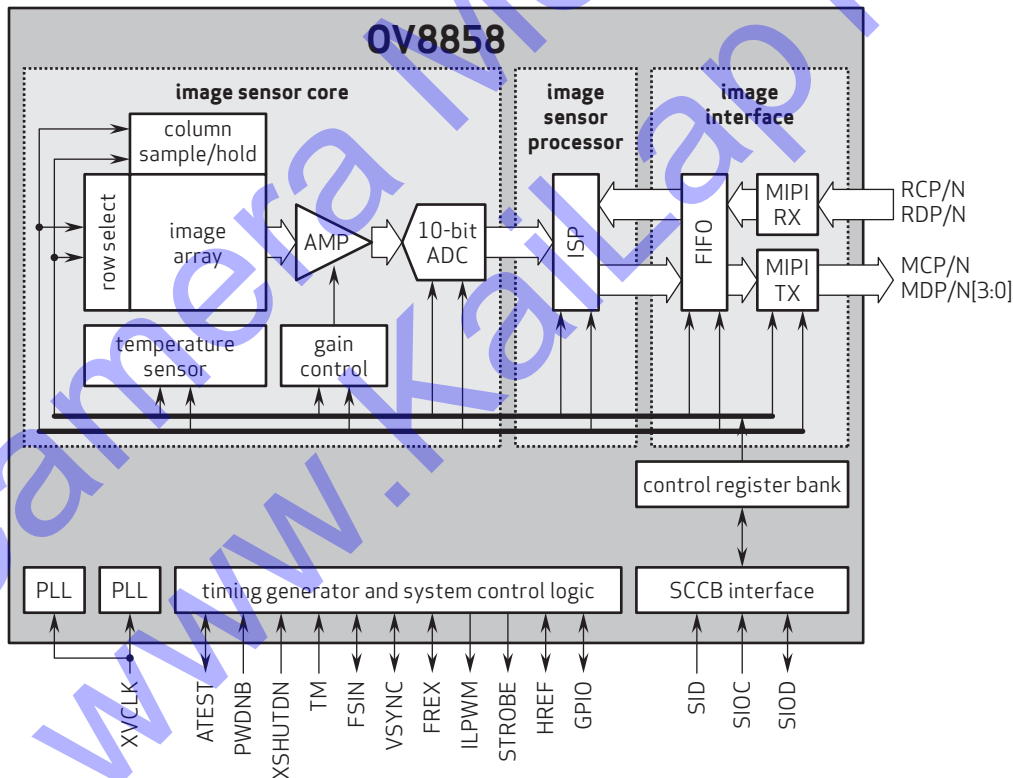

4275 Burton Drive  
Santa Clara, CA 95054  
USA

Tel: +1 408 567 3000  
Fax: +1 408 567 3001  
www.ovt.com

OmniVision reserves the right to make changes to their products or to discontinue any product or service without further notice. OmniVision, the OmniVision logo and VarioPixel are registered trademarks of OmniVision Technologies, Inc. PureCel and OmniBSI are trademarks of OmniVision Technologies, Inc. All other trademarks are the property of their respective owners.



OmniVision